

Exploded diagram of a Starter motor (Excluding the housing)

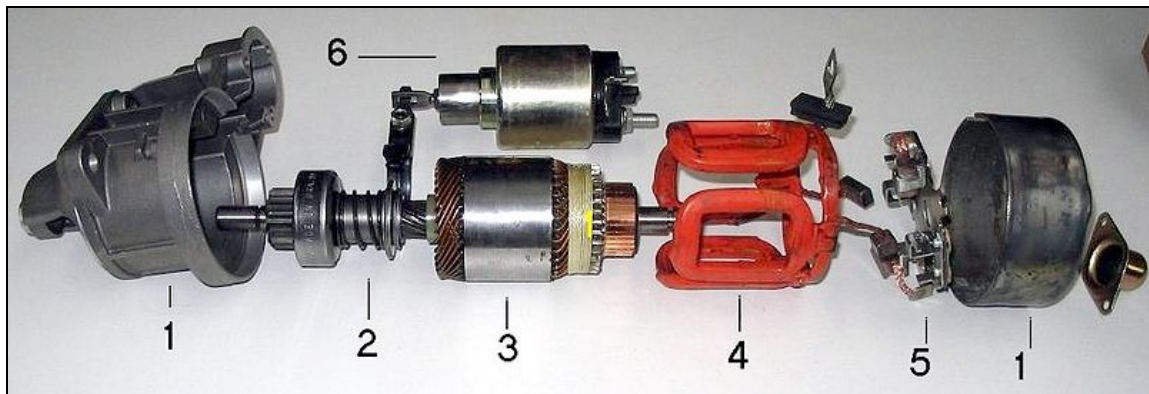

Description:

1. Main Housing (yoke)
2. Overrunning clutch
3. Armature
4. Field coils
5. Brushes
6. Solenoid

Starter Motor Installation Guide

1. Before changing the starter in the vehicle perform the necessary diagnostic tests to ensure that the starter is truly faulty.

For example:

- LISTEN to your customer, when does the problem occur (always, sometimes, after the vehicle is hot, when is cold etc.)
 - Make sure that the battery is fully charged (has a specific gravity of 1.260 or more).
 - Check all wires and cables in the starting circuit to make sure that they're in good condition (no corrosion, fraying or otherwise damaged). A voltage drop test is highly recommended.
 - Make sure all connections are clean and tight.
2. Before disconnecting the battery follow the manufacturers recommended procedures to ensure that the system memory is not compromised. Some vehicles will require that the on-board computer be re-calibrated if power is lost and some vehicles have specific window positions when disconnecting power, and if done incorrectly will cause damage or take additional time to correct. Disconnect the negative battery cable first to prevent short circuits to ground.
 3. Remove the wires and cables from the starter, marking them as necessary to ensure that they are replaced in the proper positions.
 4. Remove the mounting bolts that hold the starter in place, note the location of any bolts that are differing in length.
 5. Remove any heat shields from the old unit and install them on the new one (when applicable). Do the same with any locating pins, alignment sleeves or brackets.
 6. Clean the mounting surface of the engine or transmission, making certain it is free of any oil, corrosion or other foreign matter. Failure to do this can cause misalignment of the starter or a bad electrical connection.
 7. Place the starter on to the opening, making sure that it is aligned with the engine (or transmission on some models). Thread the mounting bolts by hand while holding the starter in the proper position. Tighten the mounting bolts to the vehicle manufacturer's specifications. **NOTE:** some vehicles with slotted mounting holes require that the starter be cranked first and then the bolts tightened. In addition some starters may require the use of shims for proper operation and to avoid premature starter failure and/or flywheel/ring gear damage.
 8. Reconnect the starter wiring, making sure to route the wires where they were originally located.
 9. Reconnect the negative (ground) cable to the battery.
 10. Start the vehicle several times, checking for proper starter operation. TIP, also allow the vehicle to run so that the system can also be checked when hot.

Starter Motor Pre-installation check (Summary):

- **65 %** of all starter failure due to a faulty or weak *battery* (batteries should be replaced every 3 years with the required correct cold cranking amps) and over cranking of the unit.
- **20%** of all starter failure is due to *poor electrical connections, fuseable links, bad battery cables and bad grounds*. Cables can be tested by verifying that the voltage drop doesn't exceed ½ volt from end to end.
- **8%** of all starter failure is due to improperly mounted starters (Dowel mounting/loose bolts).
- **7%** of all starter failure is due to improper timing and overheating

Note: Before installing a starter motor you must be certain of a fully charged battery.

Battery Test

The acid level must be along the plates and separators. OK?

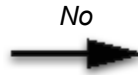

Add distilled water up to the mark or above the plates and charge battery.

Use a Volt meter to test the Battery.

Battery Condition:		
12.6 Volts	=	a fully charged battery 100%
12.4 Volts	=	75%
12.2 Volts	=	50%
12.0 Volts	=	25%
11.8 Volts	=	0%



Test specific gravity of electrolyte. Minimum value = 1.28 g/cm3 OK ?

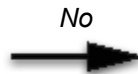

Charge battery, check regulator voltage (see KTR Alternator test procedure). Replace defective battery.

Starter does not crank engine. (Pinion meshes)

Is starter solenoid engaging? (Pinion meshes)

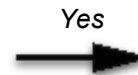

Check correct application for part number, Check battery is fully charged, if Engaging noise is audible but headlights dim when cranking: starter defective (armature or field windings shorted, commutator worn, brushes worn). Remove and replace starter. Engaging noise is audible and head lights remain bright: starter defective. Remove and replace starter.



No

Engaging noise is not audible and headlights remain bright: no voltage at solenoid terminal - ignition switch. Open circuit to ignition switch or voltage drop at ignition switch. Eliminate open circuit or replace switch. Voltage present at solenoid; starter defective. Remove and replace starter.

Starter does not crank engine. (Pinion does not mesh)

Starter solenoid engaging (Pinion does not mesh)



Damaged teeth on ring gear. Replace defective ring gear, Incorrect installation of starters; starter flange misaligned or loose. Correct installation. Damaged pinion teeth on starter. Replace starter.

Starter continues to spin after disengagement.

Defective starter (no armature braking effect). Remove and replace starter.

Starter continues to spin after disengagement.

Voltage at solenoid switch field winding terminal at least 9V (18V on 24 systems)?



Voltage drop between battery and starter solenoid battery terminal, Clean battery posts or replace battery cable (voltage drop across cables). Defective battery. See battery Test above.

Yes



Remove and clean field winding cable connections'. Defective starter (excessive voltage drop at solenoid bridge or open circuit in starter). Remove and replace starter.

Engine starts. When ignition switch is released, starter must quickly disengage and come to rest.

Starter does not disengage.

Test voltage at solenoid switch ignition terminal with test lamp. After releasing ignition switch from start position there should be no voltage at solenoid terminal. OK ?

No



Ignition switch defective. Replace Short between cable leading to ignition switch and battery cable. Repair or replace cables.

Optional current draw test

If engine manufacture's current consumption specifications are available, connect inductive ammeter on battery cable leading to and measure current draw while starter is cranking.



If current consumption is out of specification, starter cables or connections may be defective, or battery may be wrong capacity for application. **Note:** engine condition, oil viscosity and temperature will affect this test.

Common General Starter Motor Faults (Summary):

- Clicks only:
 - Poor wiring connections.
 - Defective solenoid.
 - Defective ignition switch.
 - Defective Starter Motor.
 - Poor earth connection.
- Turns slowly:
 - Poor battery condition.
 - Poor wiring connections.
 - Corroded battery cables.
 - Generally worn Starter Motor.
- Running in mesh:
 - Defective ignition switch.
 - Sticking solenoid.
 - Sticking pinion.
- Noisy in operation:
 - Loose mountings.
 - Locating dowel (if applicable) not fitted, or fitted askew.
 - Ring gear damage (although this is extremely rare the ring gear is made of hardened steel and the drive pinion is made of mild steel)
 - Defective pinion.

Starter motor Trouble Shooting Guide

Listed below are some of the more common problems that occur in Starter motors, along with some of the likely causes and remedies. Due to the number of types of units and systems that exist this is only a general listing of the most common problems, possible causes and remedies that are possible.

SYMPTOM:

Starter does not operate, or starter operates slowly

Possible Causes:

- Weak or dead battery
- Bad starting system cables or cables
- Bad ignition switch and/or wiring
- Bad starter solenoid
- Overheated engine
- Incorrect engine oil (too heavy) old oil
- Incorrect battery(CCA rating too low)

Remedy:

- Charge or replace the battery
- Repair/replace cables and connectors
- Repair/replace the switch or wiring
- Replace the starter or solenoid
- Allow the engine to cool, possibly install a heat shield on the starter. If the problem persists check the engine cooling system
- Replace oil with correct viscosity
- Replace battery with proper battery

SYMPTOM:

**Starter motor runs, but does not turn the engine over
(does not engage the ring gear or Flywheel)**

Possible Causes:

- Faulty solenoid
- Faulty ring gear or flywheel stuck
- Improper shimming/installation of the Starter

Remedy:

- Replace the solenoid or starter, check on a test bench.
- Replace the ring gear or flywheel
- Check and adjust the starter shimming/positioning, use dowel supplied. Always use all the mounting holes and ensure that all bolts are tightened to correct torque

SYMPTOM

Starter remains engaged after the engine starts

Possible Causes:

- Improper shimming of the starter
- Faulty ignition switch or solenoid wiring
- Faulty solenoid
- Starter mounting hardware is loose (starter misalignment)
- Low Voltage to the starter

Remedy:

- Check and adjust shims
- Repair or replace the wiring/switch/relay
- Replace the solenoid or starter, check on a test bench.
- Align starter and tighten bolts correctly
- Load test the battery and check the wiring for voltage drops

Burnt out Starter Motor:

The most common cause of Starter Motor Failure:

The demand for modern day starter motors to be more powerful yet smaller for weight and fitment to suit new engines does come with a problem.

The most popular fault we encounter is where a starter has literally burnt out.

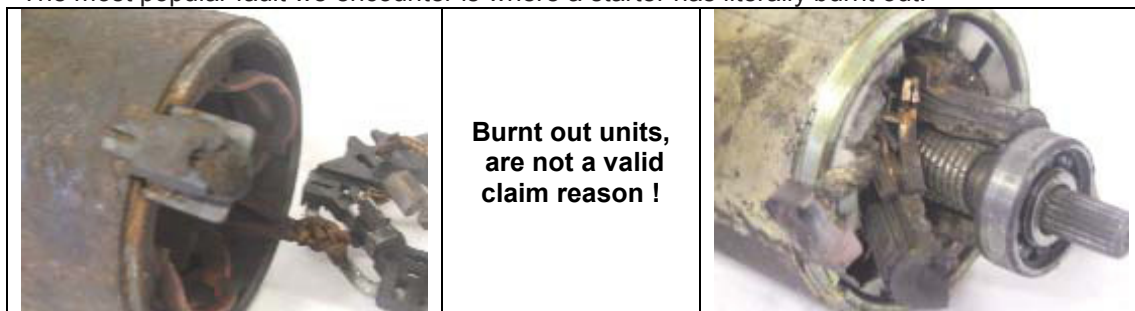

Upon inspection of a burnt out unit there are always obvious tell-tale signs:

- A strong smell of burning, often the armature will have exploded and loose metal fragments will be visible in the nose cone.
- Blue armature shaft and drive (again a sign of overheating).
- Drive teeth chewed up by the vehicles ring gear.
- A slipping drive / clutch assembly (easily identified if you can spin the starter drive by hand easily both ways).

All these faults are normally caused by the starter motor getting excessively hot.

There are a number of reasons as to why a unit gets this hot but the most common three reasons are:

A vehicle is generally a poor starter and it has been over cranked.

The vehicle runs out of fuel and again it gets over cranked.

But the final and most common fault is when the vehicle has a faulty ignition switch causing the starter to stick in mesh.

This fault occurs with all late Opel petrol and diesel starter motors and Opel will not change a starter motor without changing the ignition switch.

How to test for a Starter motor voltage drop:

One of the most overlooked tests when troubleshooting starting problems is a voltage drop test. Every electrical circuit is designed to operate on a certain amount of voltage. If the voltage is lower than what is required, proper operation will not take place. This is especially true with high current circuits, such as the starting system. Voltage drop is caused by excessive resistance in the circuit created by a bad cable or poor connection where cables are attached. Sometimes you can see the problem; Corroded battery terminals, for example, are usually quite evident. But often times the resistance can be caused by corrosion inside the cable, or by a loose or rusted connection. A voltage drop test will always identify the cause of the problem. It's fast and easy and requires only a DVOM.

How to Test:

Before you perform a voltage drop test, make certain that your battery is fully charged and in good condition. A defective or partially discharged battery will prevent you from getting accurate readings. Most auto supply stores can test the battery for you. Use the volt meter to test the battery voltage. A fully charged 12 volt battery should read 12.6 volts. If you have had the battery on a charger, it will have a surface charge on it and read higher. Remove the surface charge by turning on the headlights for one minute, then check the battery voltage again. It should come back to 12.6 volts if it is fully charged.

Voltage drop testing can be done only when current is flowing in the circuit. This means that the starter must be cranking to test the starting circuit. The important thing to remember is that the current flowing through the circuit is near the maximum amperage required for that circuit. The only tool you need is a digital volt meter. Most volt meters are auto-ranging, but some require you to manually select the scale. If you must manually set your voltmeter, select the range closest to 2 volts DC.

Step-by-step Starter Positive and Negative Voltage Drop Testing Procedure

Positive Voltage Drop Testing Procedure:

1. Verify that battery is fully charged
2. Disable ignition
3. If using an auto-ranging DVOM, set to DC voltage. If not using an auto-ranging meter, set to 2 volts DC
4. Connect the meter's positive lead to the battery positive post (Figure1, page 2)
5. Connect the meter's negative lead to the starter's battery positive terminal (Figure1, page 2)
6. While cranking the engine, note volt meter reading
7. If over 0.25 volts, high resistance is indicated. You can isolate where the resistance is located by moving the meter's leads closer to each other and measuring voltage drop across each part of the circuit. For instance, you can measure the battery post connection resistance by testing between the battery post and the battery cable terminal

Figure 1: Positive Voltage Drop Test

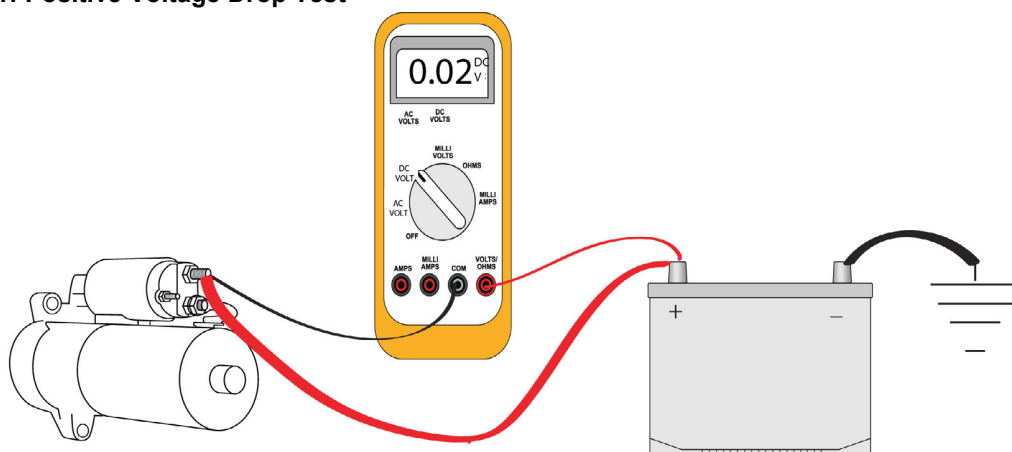

Negative Voltage Drop Testing Procedure:

1. Verify that battery is fully charged
2. Disable ignition
3. If using an auto-ranging DVOM, set to DC voltage. If not using an auto-ranging meter set to 2 volts DC
4. Connect the meter's positive lead to the starter's case (Figure 2)
5. Connect the meter's negative lead to the battery negative terminal (Figure2)
6. While cranking the engine, note volt meter reading
7. If over 0.70 volts, high resistance is indicated. You can isolate where the resistance is located by moving the meter's leads closer to each other and measuring voltage drop across each part of the circuit. For instance, you can measure the battery post connection resistance by testing between the battery post and the battery cable terminal

Figure 2: Negative Voltage Drop Test

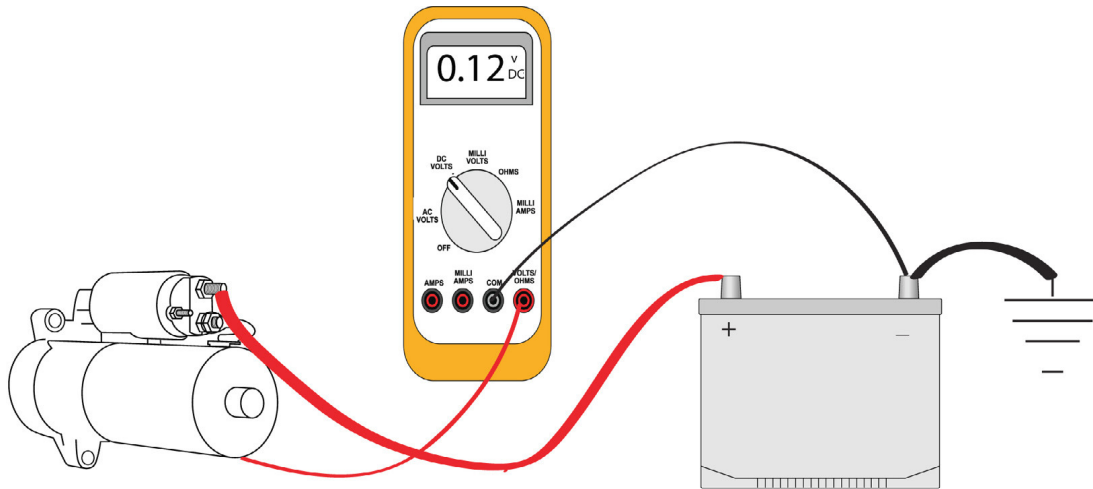

This Starter Motor has a different number of teeth?

A common situation with the Citroen, Peugeot & Renault models especially the diesel engines and a popular Mazda & KIA petrol engine, amongst numerous others. There are a number of different OE units that all look slightly different and have a different number of teeth. Despite any uncertainty on whether these units do interchange they all do, the important part is the actual pitch of the drive **NOT** the size or number of teeth.



Common when comparing a Bosch design to a Valeo design.

Citroen / Peugeot / Renault type offset starter motors with Dowel:

The distance between the starter motor drive teeth and the ring gear is critical. Starter Motors locate in to the gear box housing in two different ways in order to maintain this correct positioning.

Conventional mounting:

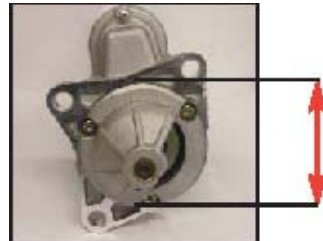

Showing diameter of bolt face

This unit has a raised circle of a precise diameter which locates in to the gear box.

Starter Motor Noise & Dowel movement:

Dowel mounting: found on most Citroen, Fiat, and Peugeot & Renault models:

Showing dowel



This unit has a locating dowel situated between the gearbox and the starter, this dowel ensures correct alignment of the unit.

Fitment Instructions:

- 1 Make sure the fitting bush (Dowel) is mounted in the starter.

This unit has a locating dowel situated between the gearbox and the starter, this dowel ensures correct alignment of the unit.

Failure to do this will make the unit noisy in operation and could cause premature failure!

(If a Dowel is not supplied with the new starter motor, remove the old starter motor and the dowel either stays in the gear box or in the nose cone of the old unit, to ensure correct alignment the dowel must be removed and refitted into the new unit.)

- 2 Hand tighten the 3 mounting bolts
- 3 The starter motor can then be moved slightly left or right
- 4 Move to the center position and tighten the bolts with 2 Newton/Meter
- 5 Start the engine and see if the starter is "quiet".
- 6 If not, loosen the bolts and move position left or right
- 7 When the starter is "quiet", tighten the bolts with 5 Newton/Meter.

Identifying VW open nose, fully supported & semi-supported Starter Motors and common faults:

There are two types of Starter Motors that are fitted to the majority of VW models. The traditional open nose type:

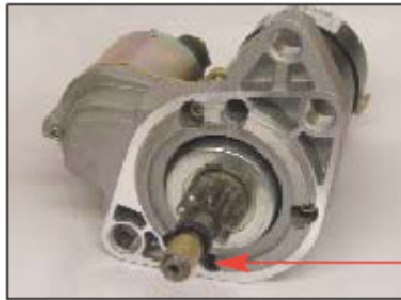

Copper bush

Picture of open nose type showing bush

This type of starter motor has a hollow copper bush which presses in to the gear box face and then the armature end of the starter locates in to this bush and supports the armature. This bush must be removed when removing the old starter motor and replaced with the new one provided.

Failure to fit this bush will cause the starter to be lazy in operation, overheating of the new unit and ultimately premature failure of the unit.





The second and newer version of the VW starter is the semi supported type or bulbous type as it can also be called.



Bulbous type

This type of Starter does not have the same style of fitment as the earlier type and does not suffer from the same fault, although the most popular failing point that we encounter is the drive pinion is chewed up.

Pal Magnetron type replacing Lucas type M50 / M127

	NEW! Pal Magnetron type	vs	M50 / M127 Lucas type
✓	No nose cone	✗	With nose cone
✓	Modern design - Gear reduction	✗	Old dated design – over 40+ Years old
			
			
✓	Will fit for M45 applications due to smaller size.	✗	Will not always fit for M45 applications do to longer overall length.
✓	Shorter	✗	Longer
✓	Lighter	✗	Heavier
✓	Easier to install.	✗	Bulkier unit to install
✓	Lower Price	✗	Higher Price (excessive copper design)
✓	Latest technology advancements included	✗	Tradition Lucas design from 1970's
✓	Longer lifespan	✗	Shorter Lifespan
✓	Available from High quality controlled suppliers.	✗	Available from wide range of low quality suppliers: India, China, Asia.
Replaces – 66925090, 66925089, 66925170, amongst others.			

Starter Brush Replacement Instructions

The following instructions apply to any starter motor which has the brush lead(s) welded to the field coil connection.

Two Brush Connection

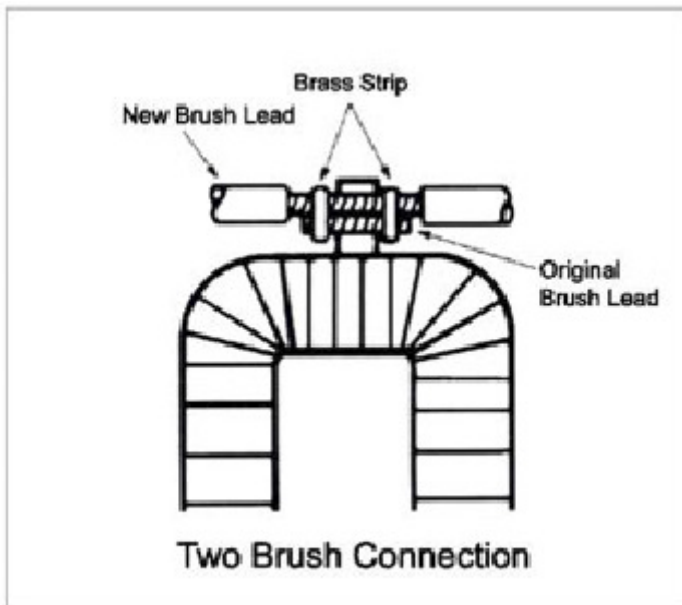

Figure 1

1. Cut the original brush leads off approx. 150mm on each side of the welded connection.
2. Using resin core 40% tin solder and a heavy duty soldering iron, tin the remaining sections of the original brush lead.
3. Position the new brush lead next to the tinned sections of the original brush lead then install crimp the brass strip connections (included) around both leads to hold the new brushes in place. **(See figure 1).**
4. Solder the new brushes in place then position the new brush leads so they do not contact the frame or interfere with through bolt installation. **(See step 2).**

Single Brush Connection

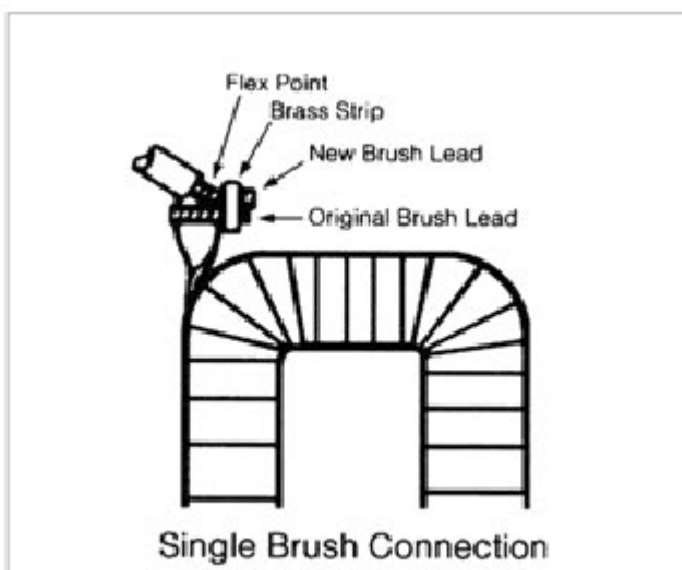

Figure 2

1. The procedure for replacing individual brushes is the same as the two brush procedure except for brush positioning. On single brush connections it is important for the new brush lead to flex at approximately the same location as the original.
2. To accomplish this, the brush should be positioned pointing in the opposite direction of the original brush.
3. Position the new brush next to the tinned section of the original brush as shown in **Figure 2**.
4. Install the brass strip connector to hold the brush in place while soldering. Make the solder connection as quickly as possible to avoid "Running" the solder up the brush lead.

OE Part number location:



Depending on the manufacturer, the Original Part number can be found in various places on the unit. OE names and part numbers are used for reference only, and educational purposes.

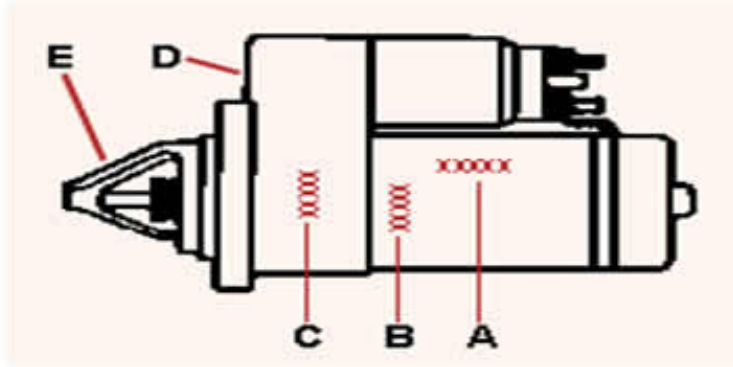

Manufacturer	Label Position	Example of Part no.
Bosch	A / B	0 001 110 023
Delco Remy	B	3471170
Ducellier	B	538005
Elmot	B	R11 12V 4KM
Femsa	B	MEA13-1
Hitachi	C	S 114-315
Iskra	A / D	AZE1515
Lucas	B	25249
Marelli	D / E	632 171 18
Mitsubishi	C / D	M3T56272
Nippondenso	A	128000-1440
Paris Rhone	B	D 9 R 84
Valeo	B / C / D	D 9 E 64

For the latest Technical info visit
www.ktr-sa.co.za
 under the Technical menu.



**KTR PART NUMBERS
 CAN BE FOUND ON
 ELECTROLOG.**

Users of the

